

Local Leak Rate Monitors



Key Features

- * ANSI/ANS 56.8 compliant
- * LLRT, LLRM, ILRT & LRM test sets
- * Measurement precision < $\pm 1.0\%$ Range
- * Pressure measurement precision < 0.1% of FS
- * High Conductance fittings & valves throughout
- * Custom leak test configurations
- * Rugged and portable
- * Simple, intuitive operation
- * Communications Interface Options
- * UKAS calibration in BS/En/ISO/IEC 17025 laboratory included

Specifications

LRM's have been built for many diverse applications and may be configured for individual plant requirements, not only for measurement ranges, accuracies and power supplies but for type of enclosure and other package considerations. The specifications below are indicative of the ranges, accuracies, options and packages available other specifications are frequently supplied, creating custom customer-focused test sets.

Typical LRM Specifications*			
Parameter	LRM100L	LRM100M	LRM103
Max. Air Leakage Range	0-30slpm	0-400slpm	0-400slpm
Leak Measurement Precision	± 0.75% of range up to 10slpm and ± 1.0% above 10slpm		
Air Leakage Repeatability	± 0.1% of range		
Air Leakage Reference Conditions	20°C & 101.325 kPa (68°F & 14.6959 psia)		
Pressure Measurement Range	Up to 0 -10 bar gauge (150 psig)		
Pressure Measurement Precision	±0.25% of FS Standard, ±0.1% of FS Optional		
Display Character Height	14mm (0.56 in)	12.2mm (0.48 in)	14mm (0.56 in)
Integrated Fast-Fill Bypass	No	No	Yes
Dual Measurement Units or Air/Nitrogen Conversion	Yes	No	Yes
Number of Valves	1	1	3
Regulator Type	Relieving as Standard, Non-relieving Optional		
Communications Options	RS232 or RS485 - Others on Request		
Mechanical*	LRM100L	LRM100M	LRM103
Case Construction	Polypropylene Copolymer (1520 Pelican Case)		Aluminium Flight Case
Case Dimensions (W x H x D)	460 x 330 x 180 mm (18 x 13 x 7 in)		430 x 360 x 270 mm (17 x 14 x 10.5 in)
Weight	12 kg (26lb)	14 kg (30 lb)	16 kg (34 lb)
Operating Conditions	LRM100L	LRM100M	LRM103
Ambient Temperature Range	+5 to +40°C (+40 to +105°F)		
Max. Operating Humidity	95% at 50°C non-condensing		
Storage Temperature Range	-10 to +60°C (+14 to +140°F)		
Power Requirements	LRM100L	LRM100M	LRM103
Line Voltage	+24vdc (supplied with universal 100-240V 50-60Hz mains power adapter)		
Power Consumption	25 watts approximate		
* Denotes typical overall ranges of parameters. Test sets for applications outside these ranges may be requested.			

Calibration & Support Equipment

The integrity of all measurement systems may only be maintained by periodic calibration against a known standard (rather than "automatic or self calibration". Users will often have existing local transfer standards but for those without, Chell has developed standards rugged enough for on-plant verification and for return annually to an accredited calibration laboratory. One such standard is the FMS1000-3C which is an invaluable calibration verification tool to support a fleet of LRMs.

It allows field verification of the precision of your leakage readings and doubles as a tool to train and test new LRM operators by creating known leaks on demand.

Front Panel Layout

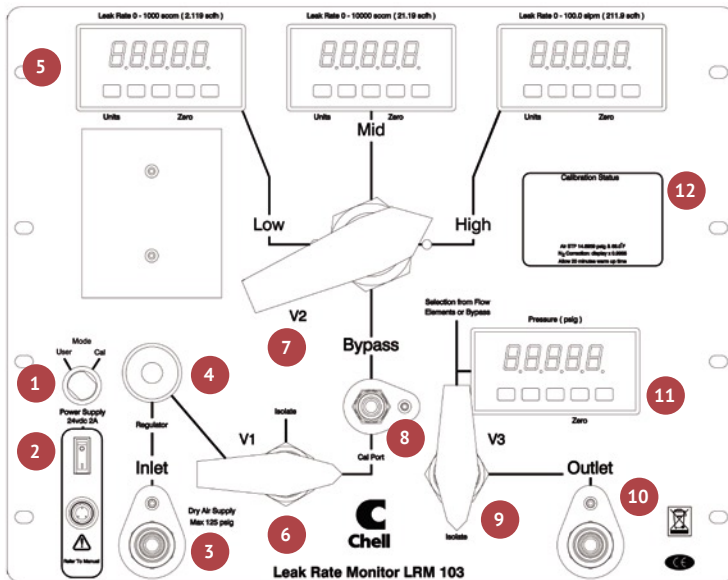

1. Calibration mode selector.
2. Switched input power connector.
3. 3/8 inch Inlet Port.
4. Precision Pressure Regulator.
5. Large, high brightness Flow Displays.
6. High Conductance Inlet Isolation Valve.
7. Range & Fast-fill Bypass selector Valve.
8. Calibration Port
9. High Conductance Inlet Isolation Valve.
10. 3/8 inch Outlet Port
11. Large, high brightness Pressure Display.
12. Calibration Conditions Statement.

Typical LRM Pneumatic Circuit

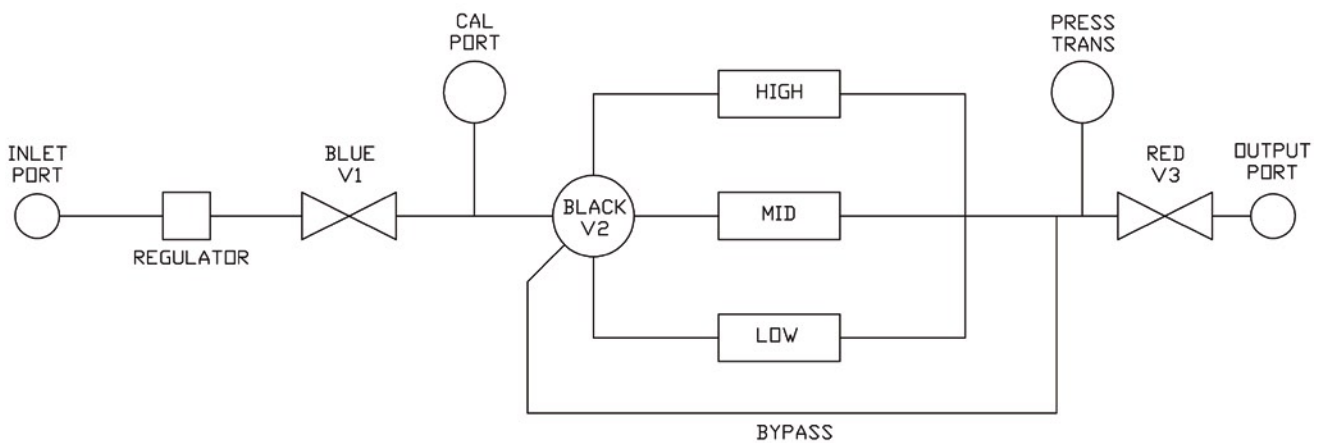

Design Concept for Reliability & Serviceability

Chell LRMs are designed and built by engineers for use by engineers and in corporate over 30 years of improvements to existing designs based on customer feedback. Rarely are two leak test requirements the same, so that a generic test set will often have compromises either in operation or, more seriously, in performance. All the Chell LRM family of instruments have been designed to meet customer-specific requirements and so bear no compromises at all. Apart from

the obvious need to select the most stable and repeatable pressure & flow measuring instruments, LRMs are designed for utmost reliability and use the highest quality valves and fittings. Components are selected for their worldwide availability so that in the unlikely event of a failure, repairs may be easily effected in the field, thus reducing downtime. Component accessibility is aided by the design layout giving fast, easy access to all components. The design has no proprietary firmware-

controlled functions that might hinder use in the field in the event of processor failure. There are no pneumatic compromises within the LRM, all conductances are of similar proportions so that internal pressure drops are minimised, thus avoiding virtual internal leaks. Although weight-reduced, the internal valves remain heavy, which adds to the overall weight of the instrument.

Another Power Generation product offered by Chell :

Air In-Leakage Monitor - AIM100

Excessive air in-leakage and ineffective non-condensable gas removal can lead to condenser inefficiencies of over 20%. One generator recently estimated the cost of air in-leakage on a 500MW turbine as in excess of £1600 (\$2400) per mbar (0.03inHg) per week. In addition to the increased generation costs, the man hours taken to locate the source of the leak are a major concern.

AIM enables trends to be picked up at an early stage and relevant corrective action to be taken. Once air in-leakage is detected, comparison of the individual Measured parameters under differing plant load conditions with historical data and with other plant measurements, is useful in indicating the most likely source of leak.

Continuous output of all the measured parameters via 4-20 mA signals and RS232 or 485 interfaces allow data logging, further analysis of the information, trending and full integration into the plant management system. Users also report much faster plant start-up after shut-down or maintenance.



Design Philosophy

High integrity testing requires that all leaks be measured under controlled pressure conditions and that accuracy and repeatability are maintained. This is achieved by the use of a sensitive, stable pressure regulator controlling the inlet conditions.

Many variations for controlling pressure, pressure rise and fixed flow have been built for the most demanding of applications. The resulting Leak Rate Monitor may be packaged either as a laboratory bench instrument or as a portable, rugged in-plant test system complying with ANSI/ANS 56.8 for both B & C type testing.

Chell's design philosophy includes the simplification of user operation, improved measurement sensitivity and precision and reduced operational maintenance. Each design offers large, easily visible LED displays for clear and unequivocal leak rate and pressure readings in both low and high brightness environments. The most popular configuration consists of a display of the applied leak test pressure with up to three displays of differing, overlapping leak rate ranges.

Each design offers large, easily visible LED displays for clear and unequivocal leak rate and pressure readings in both low and high brightness environments. The most popular configuration consists of a display of the applied leak test pressure with up to three displays of differing, overlapping leak rate ranges. The operator has only to attach to a penetration, open the isolation valve, adjust the precision regulator to the required test pressure and read the resultant leakage rate.

Direct leak rate measurements are made using high precision Thermal Mass Flow Meters that are inherently immune from the effects of varying gas and ambient temperatures, thus removing the most common leak rate instrument errors.

Specify Your LRM

Every power plant has its own individual design parameters. To specify the LRM for your exact needs refer to the configuration form at :

www.chell.co.uk/product_details/power-generation/portable-leak-rate-monitors